

FAST BIKER BIKE RACK

A captivating urban masterpiece that seamlessly combines form and function. Designed for two to four bikes, it features a unique two-point locking system for enhanced security. This rack effortlessly blends artistry with practicality, creating an inviting space for cyclists to confidently park their bikes.

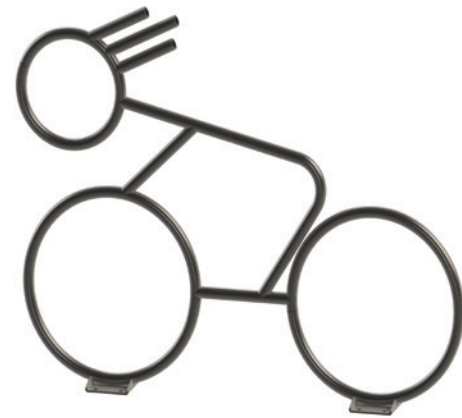

 x 4 COST \$\$\$\$

DIMENSIONS

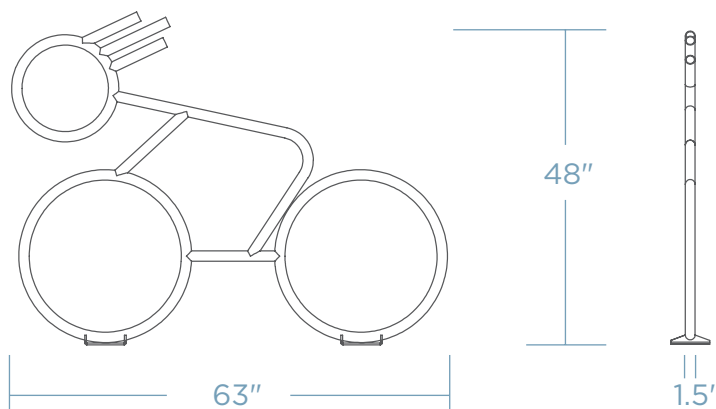

Weight - 48 lb
Schedule 40 Pipe

MOUNTING OPTIONS

SURFACE MOUNT

IN GROUND



FINISH OPTIONS

POWDER COAT

GALVANIZED STEEL

THERMOPLASTIC*

STAINLESS STEEL*

* will incur additional cost



QUANTITY _____

CUSTOMER _____

COLOR _____

PROJECT _____

DATE _____

APPROVED BY _____