

SLAT TRASH RECEPTACLE

A robust and stylish solution for efficient waste management in public spaces. Crafted from durable slatted steel, its modern design adds a contemporary touch. The outer shell is coated with textured polyethylene for enhanced durability and a sophisticated appearance. With a generous 32-gallon capacity and a range of color options, the Slat Trash Receptacle seamlessly combines strength and style, providing a reliable waste disposal solution for any outdoor environment.



COST \$\$\$\$

DIMENSIONS

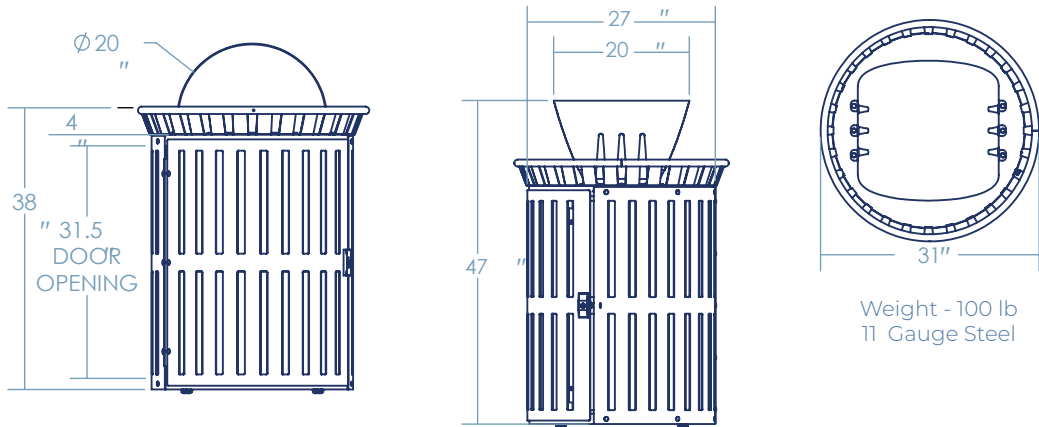

LID OPTIONS

FLAT TOP



RAIN BONNET

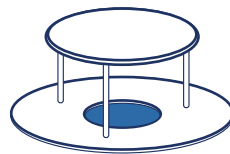

ASH TRAY

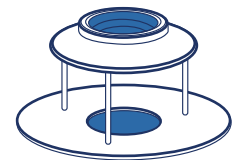

RECEPTACLE TYPE

TRASH

RECYCLING

CAPACITY

32 GALLON

44 GALLON

FINISH OPTIONS

POWDER COAT

GALVANIZED STEEL

THERMOPLASTIC*

STAINLESS STEEL*

* will incur additional cost



QUANTITY _____

CUSTOMER _____

COLOR _____

PROJECT _____

DATE _____

APPROVED BY _____