

DUAL SLAT RECEPTACLE

A versatile and space-saving solution that seamlessly combines trash and recycle functionalities in one sleek design. Crafted from durable slatted steel, this innovative receptacle offers a modern aesthetic while maintaining robust functionality. The outer shell is coated with textured polyethylene for enhanced durability and a refined appearance. With dedicated compartments for both trash and recyclables, encouraging responsible waste disposal in public spaces. Choose from a variety of colors to complement your environment, and enjoy the convenience of a 32-gallon capacity for each compartment. Elevate the sustainability of your outdoor space with the Dual Slat Receptacle – where strength, style, and eco-consciousness converge. Complete the ensemble by pairing it with our matching Slat Bench for a cohesive and functional outdoor furniture combination.



COST \$\$\$\$

DIMENSIONS

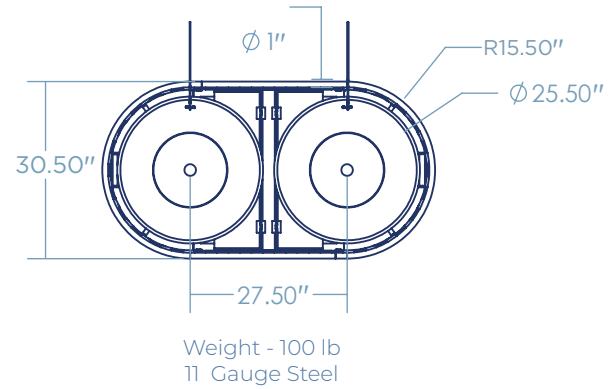
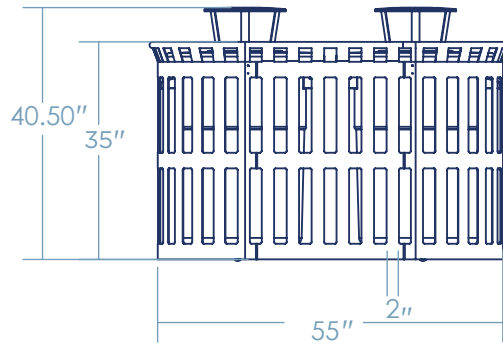

LID OPTIONS

FLAT TOP



RAIN BONNET

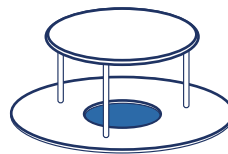

ASH TRAY

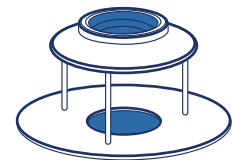

RECEPTACLE TYPE

TRASH

RECYCLING

CAPACITY

32 GALLON

44 GALLON

FINISH OPTIONS

POWDER COAT

GALVANIZED STEEL

THERMOPLASTIC*

STAINLESS STEEL*

* will incur additional cost



QUANTITY _____

CUSTOMER _____

COLOR _____

PROJECT _____

DATE _____

APPROVED BY _____