

AIR STATION

Introducing our rugged Air Station equipped with a built-in pressure gauge – a true powerhouse designed to withstand the elements of the great outdoors or seamlessly complement any indoor bike haven. Crafted for durability and performance, this heavy-duty air station is available in a versatile floor-mount option for added convenience. Elevate your biking experience with this reliable station that effortlessly blends rugged resilience with refined functionality, ensuring you're always ready for the road ahead.



COST \$\$\$\$

DIMENSIONS

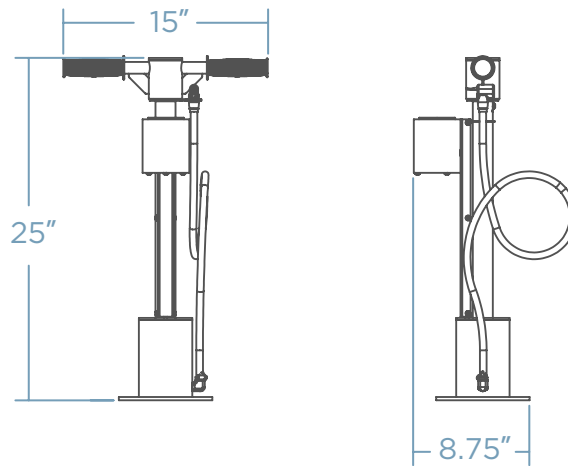

Weight - 29 lb

MOUNTING OPTIONS

SURFACE MOUNT



FINISH OPTIONS

POWDER COAT

GALVANIZED STEEL

THERMOPLASTIC*

STAINLESS STEEL*

* will incur additional cost



QUANTITY _____

CUSTOMER _____

COLOR _____

PROJECT _____

DATE _____

APPROVED BY _____